

ESMIL

EQUIPMENT

EQUIPMENT AND TECHNOLOGIES
for wastewater treatment

www.esmil.eu

ESMIL Flow Shut-off and Control Equipment

High standard of quality and reliability.



A wide range of manufactured equipment allows solving even the most complex problems of liquid flow control, level control and/or full flow shut-off.



Advanced manufacturing and quality control technologies ensure high reliability and tightness of the manufactured equipment.



The manufactured penstocks are designed for installation in channels, ducts of any size and shape (mainly rectangular, round and semicircular), open or closed ducts and on pipelines. They can also work in gravity tanks or under pressure.



Simplicity and ease of operation, along with the high quality of the materials used, the mechanical reliability of the structure and the automation capabilities make it possible to effectively use ESMIL penstocks in various climatic and operating conditions.

MAIN APPLICATIONS:



Wastewater treatment plants;



water treatment plants;



local industrial wastewater treatment plants;



hydraulic engineering and reclamation structures.



PENSTOCKS TYPES AND APPLICATION

» **HIGH-PRESSURE PENSTOCKS** are used to completely shut off the flow (open/close) in closed channels and ducts, predominantly rectangular, round and semicircular, on pipelines, in gravity tanks or under pressure. When the gate is open, the flow of liquid in the channel passes through the lower part of the frame. If it is required to shut off the flow, the operator turns on the electric drive or turns the handwheel to rotate the shaft, which is connected to the lifting screw and transfers the force to the penstock gate. The gate goes down and blocks the flow of liquid in the lowest position..

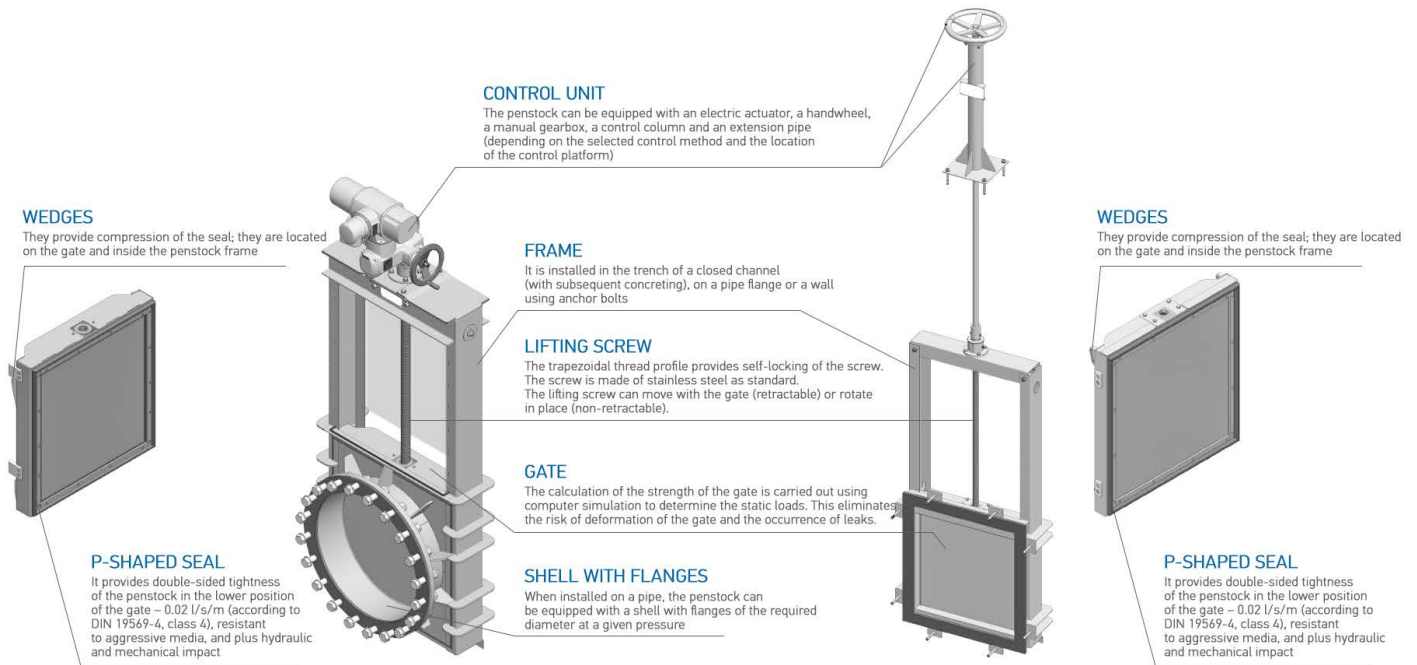

» **OPEN-CHANNEL PENSTOCKS** are used for complete blocking of the flow (open/close) in open channels and ducts of mainly rectangular, round and semicircular shape, and in gravity tanks. When the gate is open, the flow of liquid in the channel passes through the lower part of the frame. If it is required to shut off the flow, the operator turns on the electric drive or turns the handwheel to rotate the shaft, which is connected to the lifting screw and transfers the force to the penstock gate. The gate goes down and blocks the flow of liquid in the lowest position.

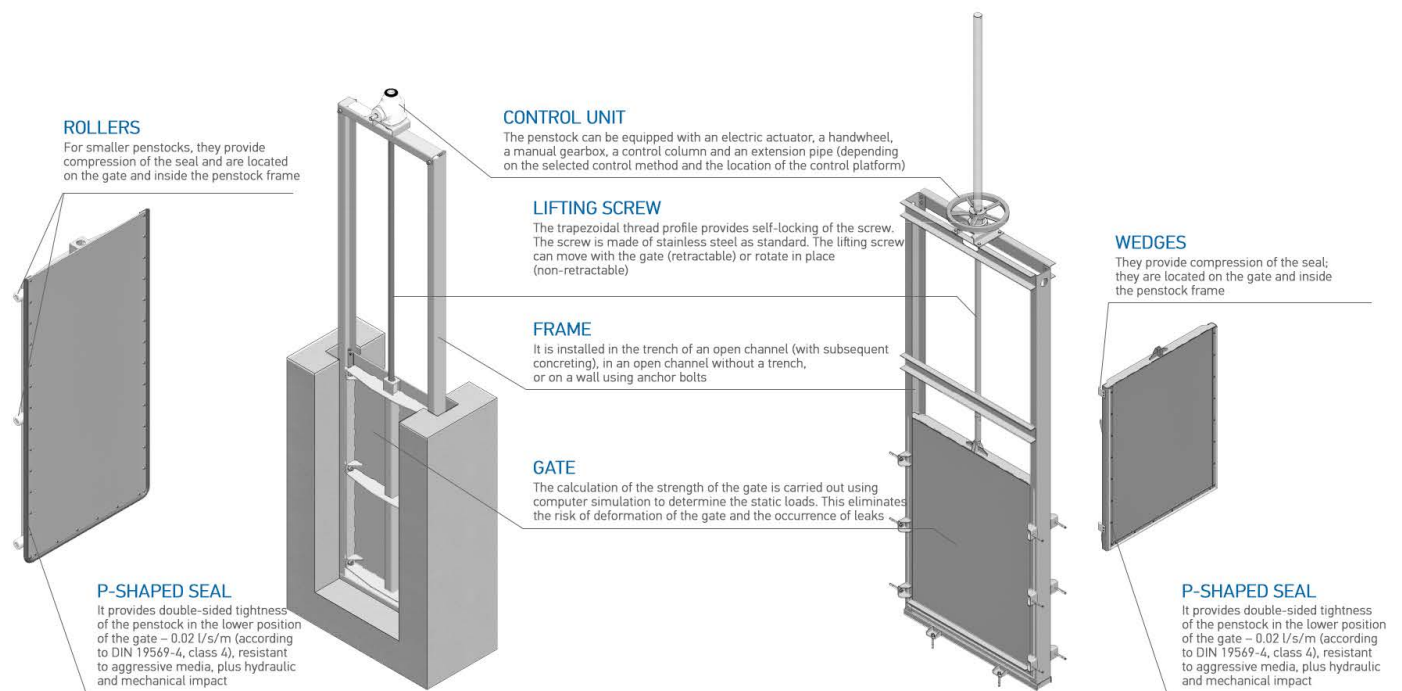

» **CONTROL PENSTOCKS** are used for the regulation of the liquid level, including the complete shut-off of the flow (without pressure) in gravity tanks, in open channels and ducts. An open sluice gate allows liquid to flow through the top of the frame, with the gate overflow edge at the MIN level. Partial or complete shut-off of the flow is carried out by raising the gate using a lifting screw controlled by a hand wheel or electric motor, while the overflow edge of the gate cannot be raised above the MAX level. The gate can be fixed at any height from MIN to MAX, which ensures the required liquid level. The screw is fixed directly on the gate and moves with it (retractable).

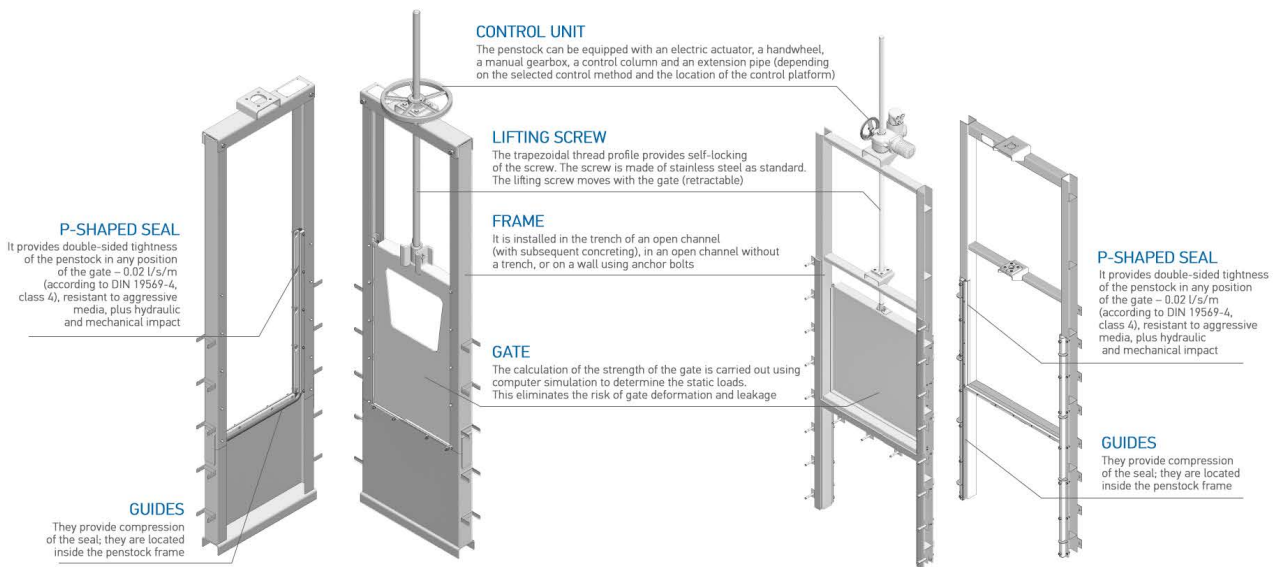

» **STOPLOG GATES** are used for temporary shutting-off during repair and installation work in gravity tanks and open channels. The gate is lowered into the frame with the help of lifting devices, providing a temporary leak shut-off of the flow during the period of repair and installation work. The gate blocks the flow in the lower position, enters the frame body through the hollow upper bar and moves down touching the side guide bars to the lower bar.

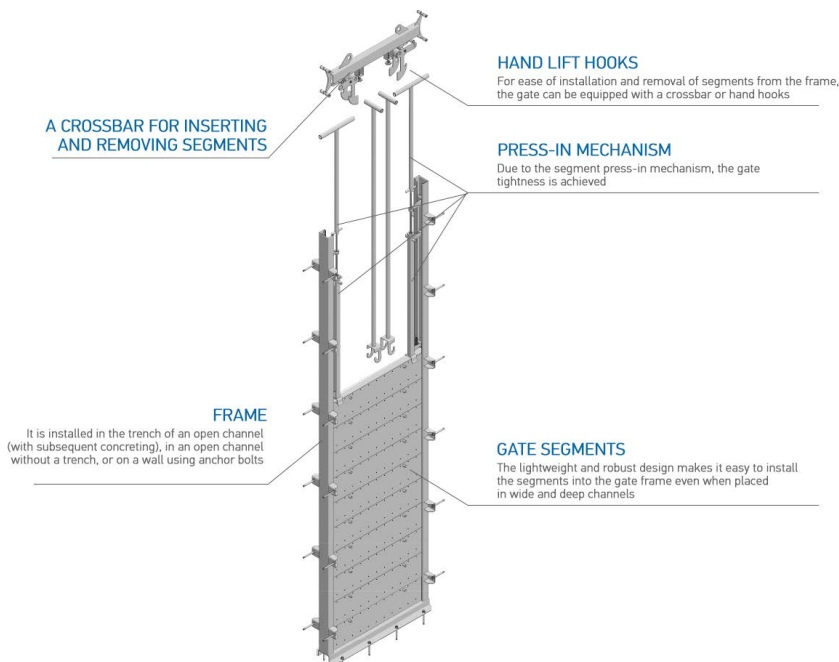
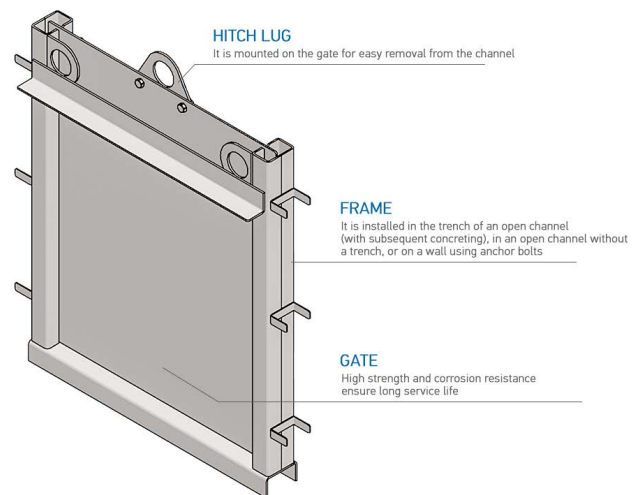

» **MODULAR STOPLOG GATES** are used for maintenance and repair of the main penstock installed nearby, for redistribution of flow in gravity tanks and open channels. The gate segments are installed in a frame mounted in the channel to temporarily block the flow. A seal is provided between the gate segments, which, in combination with the clamping mechanism, increases the tightness of the gate in the closed state.

» **REPELLING OVERFLOW** is used for regulation and maintenance of a constant liquid level in channels and reservoirs. Starting the drive causes the screw to turn and the gate is raised/lowered to a predetermined position of the overflow operation, corresponding to a specific liquid level in the overflow channel or reservoir. To ensure tightness, a seal is installed on the side vertical walls of the gate frame. The tight fit of the seal to the frame walls prevents leaks on the side edges of the gate.

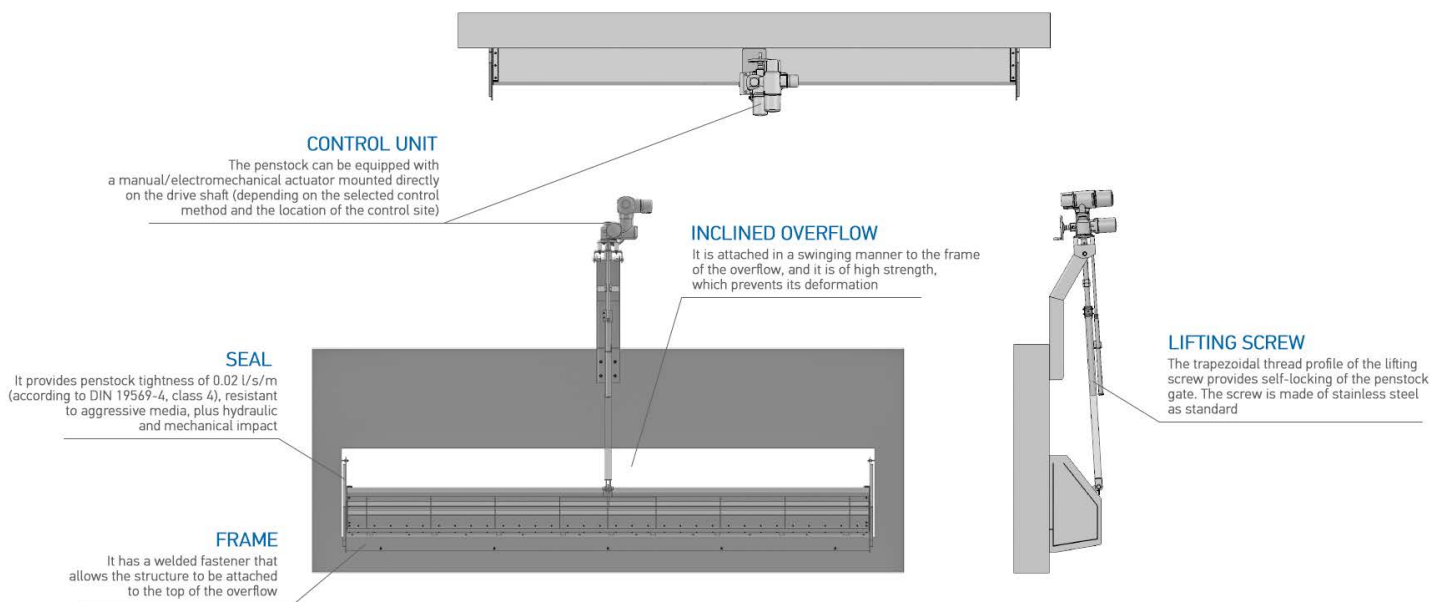

» **FLOW SPLITTER** is designed for splitting the flow (full/partial), regulating and changing the direction of flow in channels and tanks. The flow is controlled by changing the position of the penstock gate in relation to the direction of flow. Sealing gaskets are installed on the sides and the bottom of the gate to prevent leaks after closing the drain channels.

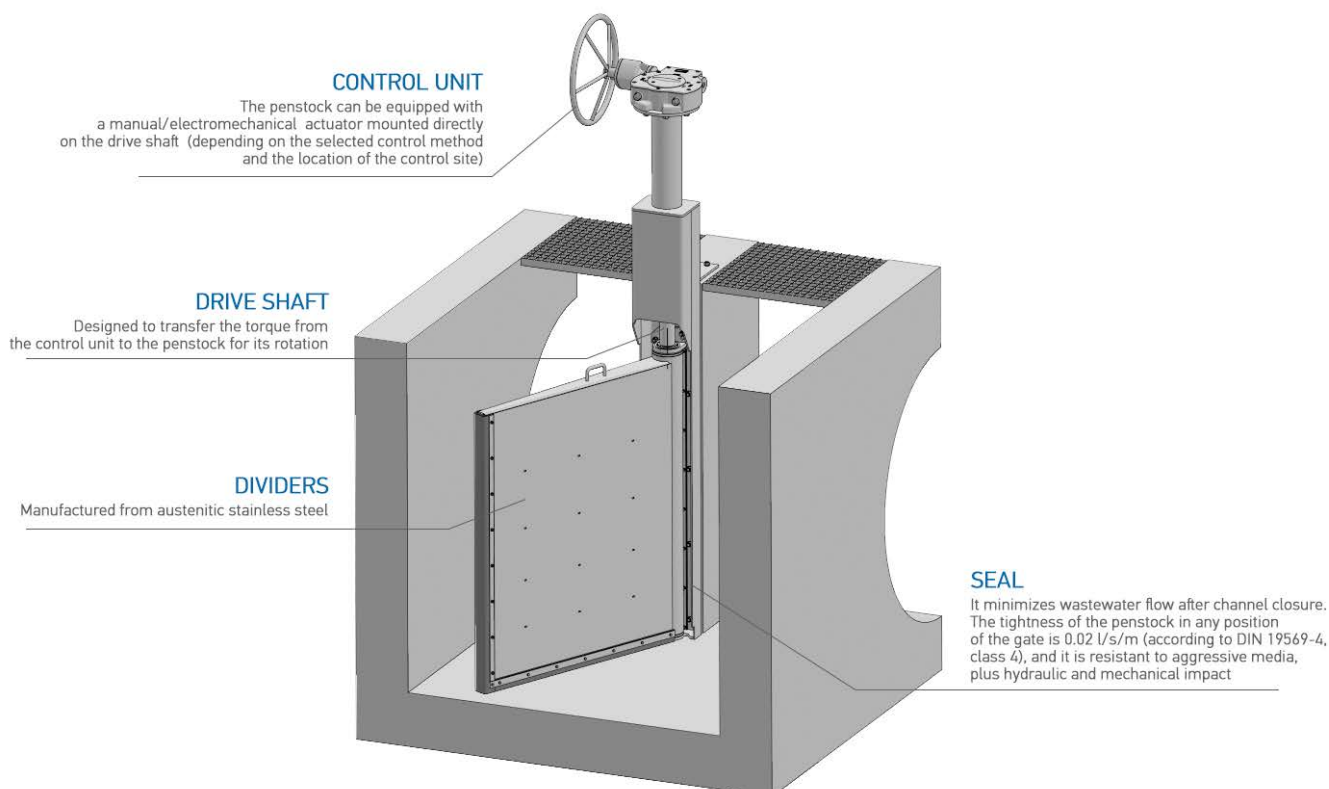

ADVANTAGES AND EFFECTIVE TECHNICAL SOLUTIONS

Tightness complying with the highest standards

- » The penstocks can withstand hydrostatic pressure of up to 1 bar, optionally higher. Permissible leakage rate is 0.02 l/s/m (according to DIN 19569-4, class 4).
- » The equipment is checked for leaks at the factory test bench, which ensures quality control of the products, and also allows achieving a higher level of tightness.
- » Sealing of the manufactured penstocks ensures their operation in one- and two-way flow directions. The seal of the valves is made of EPDM (optional NBR), which is highly resistant to aggressive media and hydraulic and mechanical impact.

Reliability and Durability

- » Perfect association of casing parts and mechanisms due to the use of high-precision manufacturing technologies.
- » High corrosion resistance achieved by using stainless steel AISI 304, AISI 316 (other types on request), plastic and bronze.
- » After welding, the product goes through a full cycle of anti-corrosion treatment: volumetric (acid) etching and passivation by special means.

Ease of Operation and Maintenance

- » The use of high-quality components and time-tested technical solutions ensures a long service life of the equipment and minimizes the need for maintenance.
- » During operation, maintenance is limited to periodic replacement of the seal and lubrication of the screw and bearings, which ensures low operating costs and decreased maintenance personnel working hours.
- » The design of the penstocks allows for easy replacement of the seal.
- » Optionally, a transparent cover for the sliding screw can be made to protect it from dirt and allow visual control of the opening of the gate; a cover for the ground part of the frame can also be provided.

Control and Automation

- » Gearmotors from leading European manufacturers (AUMA, ROTORK) with frequency control, which allows flexible control of the equipment operation and significantly reduces energy consumption.
- » The built-in supervision function allows remote monitoring of the operating status of the control cabinet as a whole (dry contacts).
- » Electrical protection against overload and power surges is provided.
- » The Ingress Protection Rating of the electric drive is IP 68, which allows immersion into the water to a depth of 1 m.
- » The penstock with an electric drive is equipped with a control cabinet and (on request) a control unit (MATIC, AUMATIC), which is fully configured at the production plant, which allows the gate to be put into operation without additional efforts on the part of the customer.
- » The penstocks can (on request) be designed with the possibility of replacing the handwheel with an electric drive or a manual gearbox.

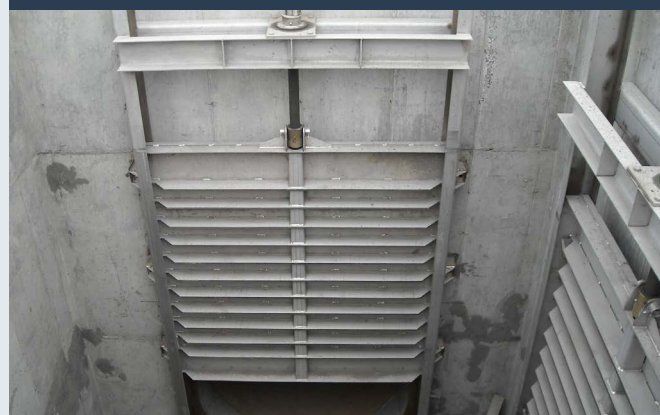
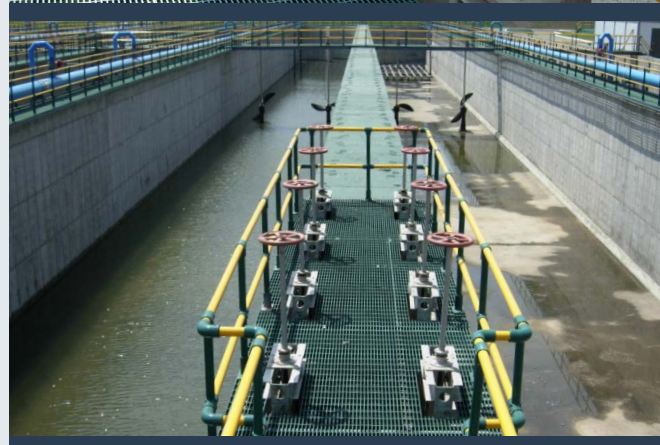



Individual approach and high reliability

- » A flexible design approach allows it to be customized to specific requirements and locations.
- » A wide range of configuration options will satisfy the requirements of even the most demanding customers.
- » The Customer can get advice directly from the leading specialists of the company in the shortest possible time. They can also get assistance in solving possible design and delivery issues.

TECHNICAL SPECIFICATIONS

Parameter Description	Value
Frame width/height, m	0.3÷3.0/0.7÷6.2* (greater sizes on a special order)
Gate height, m	0.3÷3.0
Gate closing/opening time, min	1÷6
Lifting screw	retractable/non-retractable
Gate metal thickness, mm	3÷6
Frame metal thickness, mm	4÷6
Plastic grades used	polyamides PA6, PA610
Screw diameter	30x6÷80x10 (trapezoidal thread)
Sealing	EPDM – standard, NBR – optional
Service life of the seal, opening/closing cycles	500
Permissible leakage, l/s/m	0.02 (smaller sizes on special order)
Hydrostatic pressure, m H2O	up to 10 (higher pressure on special order)
Brands of electric drive used	AUMA, ROTORK
Ingress Protection Rate of the drive (default)	IP 68
Handwheel diameter, mm	Ø300-500
Placement of the control element	on the frame / on the outrigger
Supply voltage, V	380 – 420
Mains frequency, Hz	50

ESMIL Group
International Sales Department

+48 87 620 06 02
 prodeko@esmil.eu